



TAKE-UPS & WINDING SYSTEMS

GLOBAL WINDING SOLUTIONS

For textiles, paper, plastic film rolls - *Tessile, carta, film plastici* - In Textil, Papier und Kunststoffolie - *Pour l'industrie du textile, papier, film plastique*
 - En el sector textil, papel, película de plástico - *Na indústria têxtil, papel, filme plástico* - *Tekstil, kağıt, plastik film tesislerinde*
Текстиль, бумага, полиэтиленовая пленка, упаковка - نداعمل افيل غتلا و ةئبعتلا قفارمو ،مل يف كيئتس ال بل او ق رول او تاج و س نمل ل اجم يف



AS03-AXIAL BATCHING UNIT - AVVOLGITORE ASSIALE AS03



Applications- Applicazioni- Anwendungen- Aplicaciones- Aplicações- Uygulamalar - приложений – تاق يبطت



Glass, carbon, automotive, aeronautics, special technical fabrics, long loop terry - Vetro, carbonio, settori auto ed aeronautica, tessuti tecnici speciali-

Glas, Kohlenstoff, Automotive, Luftfahrt, spezielle technische Gewebe, Hochfloriges Frottier - Pour verre, carbone, automobile, aéronautique, tissus techniques spéciaux.

Para los sectores de vidrio, carbono, automóviles, aeronáutica, tejidos técnicos especiales. Para os setores de vidro, carbono, automotiva, aeronáutica, tecidos técnicos especiais.

- Cam, karbon, otomotiv, havacılık, özel teknik kumaşların sektörler için. – для секторов из стекла, углерода, автомобильных, воздухоплавания, специальных технических тканей.

قصاخلا ئىنقىتلا قشحقال او ،ناريطل او ،تارايسل او ،نوبركل او جاجزلا تناعاطقل



The axial automatic take-ups AS-03 , coupled to the loom, allow the formation of large rolls of fabric. The machine works with direct drive of the central axis and controls by load cell, PLC, microprocessors, Touch Screen.

L'arrotolatore automatico AS-03 accoppiato al telaio tessile, permette la formazione di grandi rotoli di tessuto. La macchina lavora con azionamento diretto dell'asse centrale e controlli tramite PLC, microprocessori, cella di carico, Touch Screen.

Electronic control of the parameters of winding by means of electronic load cell amplified.

The system allows to select the program as a function of different types of fabric

The software allows the operator to choose recipes more fit for purpose.

It is a digital servo for textile looms, equipped with the necessary software for different applications. The software allows you to program and to electronically control the winding tension, the torque of the clutch, the strength of the pressure cylinder. The innovation of this system is the possibility to program the parameters of the winding process, with special profiles from the beginning up to maximum diameter. The winding parameters are reproducible and can be stored.

I controlli elettronici dei parametri con cella di carico elettronica amplificata

In grado di creare e selezionare diversi profili di tensione durante il processo di avvolgimento.

Si tratta di un servo-azionamento digitale per telai tessili, equipaggiati con il software necessario per diverse applicazioni. Il software consente di programmare e di controllare elettronicamente la tensione di avvolgimento, la coppia della frizione, la forza del cilindro pressore. L'innovazione di questo sistema è la possibilità di programmare i parametri del processo di avvolgimento, con profili speciali dall'inizio fino al diametro massimo. I parametri di avvolgimento sono riproducibili e possono essere memorizzati.



Color Touch screen “Touch screen” a colori

Via the interface HMI the operator controls all the key parameters that influence the winding, and also has the ability to intervene to make any changes to default settings.

The measurements are taken at all times.

The system is prepared for the programmed stop in order to allow the cutting of the fabric to the achievement of the predetermined diameter (or meters of products)

Tramite l'interfaccia HMI l'operatore controlla tutti i parametri fondamentali che influenzano l'avvolgimento, ed ha anche la possibilità di intervenire per apportare eventuali modifiche alle impostazioni iniziali. I dati sono rilevati in ogni momento.

Il sistema è predisposto per l'arresto programmato onde consentire il taglio della tela al raggiungimento del diametro prefissato (o dei metri prodotti)

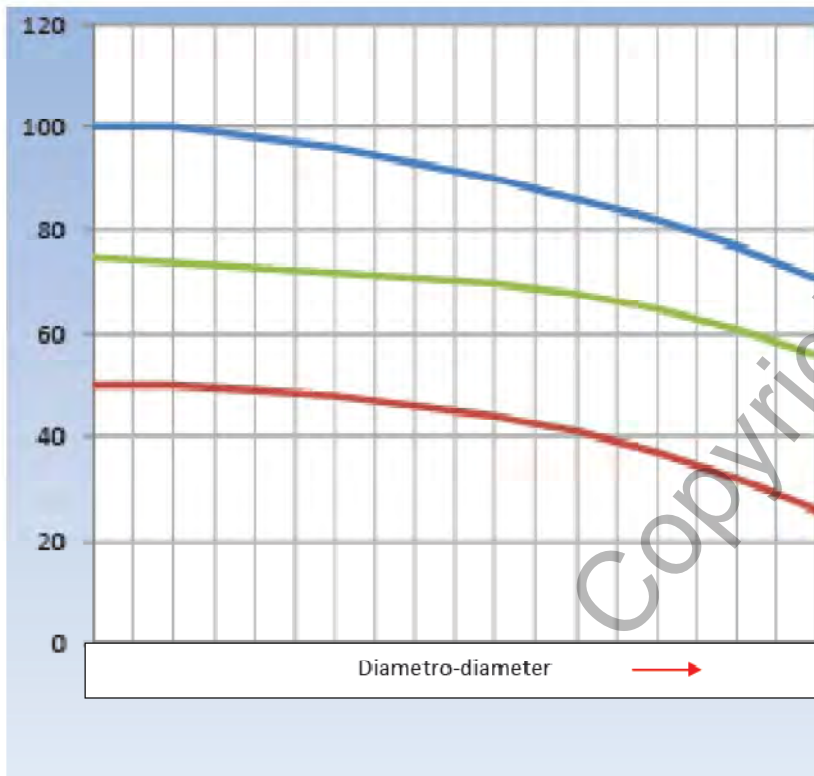
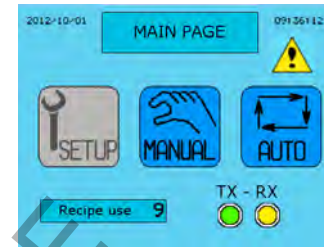

TENSION TENSIONE
 FRICTION FRIZIONE
 PRESSURE -PRESSIONE

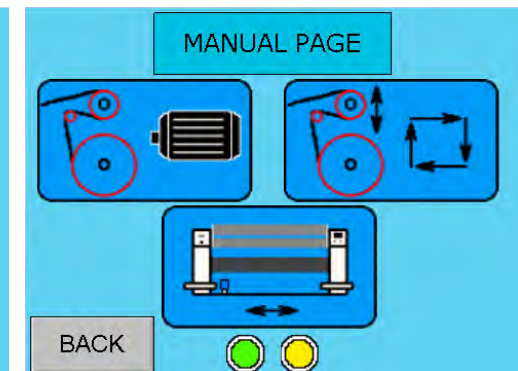
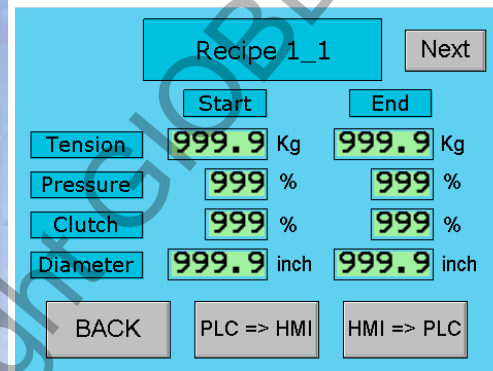

The curves are defined by points with their values, including the pulling force (%), the torque of the clutch, the force of the pressure roller and the length (m). A total of 1024 curves can be stored. The selection of the winding recipe of the fabric is handled by the touch screen panel, on the console of the machine.

Le curve sono definite da punti con i loro valori, comprendenti il tiro (%), la frizione, la forza del cilindro pressore e la lunghezza (m). Un totale di 1024 curve può essere memorizzato.

La selezione del profilo di avvolgimento del tessuto viene gestita dal pannello touch screen, sulla consolle della macchina.

The tangential automatic take-up ES, coupled to the loom, allow the formation of large rolls of fabric. The model uses a sensor commuter and INVERTER vector driver for accurate control of winding parameters.

Gli arrotolatori tangenziali automatici ES accoppiati ai telai, consentono la formazione di grandi rotoli di tessuto. Il modello utilizza un accurato sensore pendolare ed azionamenti ad INVERTER vettoriale per un accurato controllo dei parametri di avvolgimento.



Take-up with inclined inspection table

Special take-up for technical fabrics - **Avvolgitore speciale per tessuti tecnici** - Sonder Wickler für technische Gewebe - **Enrouleur spécial pour les tissus techniques** ES- especial para tejidos técnicos - **Enrolador especial para tecidos tecnico** - Teknik kumaşlar için özel sarıcı - **Специальный намотки для технических тканей** –
 دین قتلہ قش مق آلل صاخ فاسللا

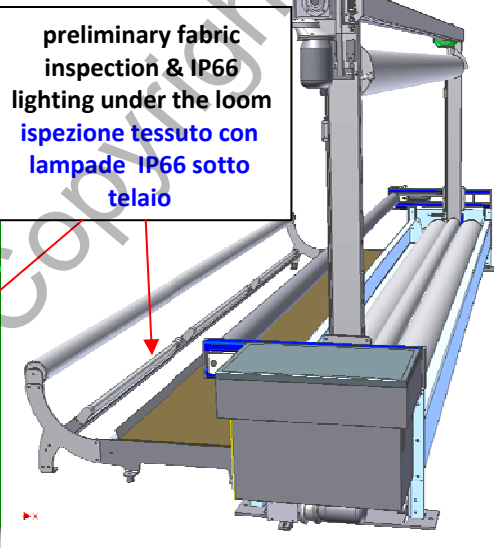
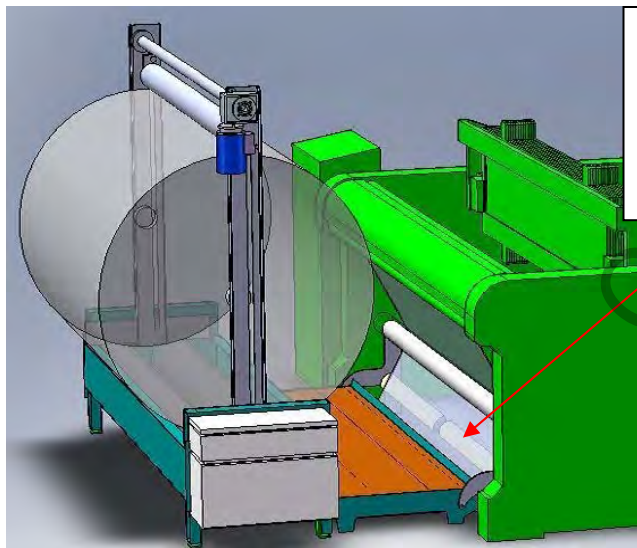

preliminary fabric inspection & IP66 lighting under the loom
 ispezione tessuto con lampade IP66 sotto telaio

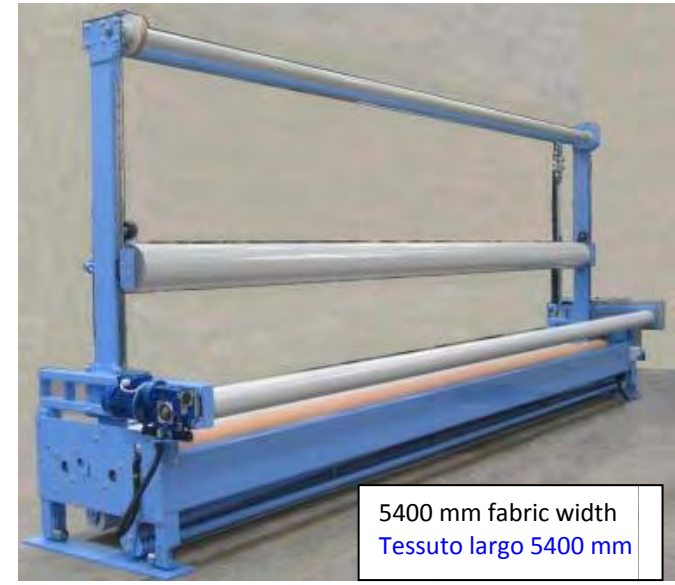

5400 mm fabric width
 Tessuto largo 5400 mm

CATWALK with anti-sliding surface on the platform by use of birch wood-resin 15 mm thickness to prevent also vibrations from the loom to the weaver.

Passerella in legno di betulla resinato, con superficie anti-scivolamento, spessore 15 mm per smorzare le vibrazioni dal telaio al tessitore

Also available with step - Disponibile anche con gradino

Automatic electric fabric roll ejection system-

Sistema elettrico automatico di espulsione del rotolo di tessuto



FERBER motorized system of roll ejection through the cylinder having a central shaft with sliding gears motorized on guarded side racks, which are able to impress to the roll an impact at constant and smooth speed

Sistema FERBER motorizzato di espulsione avente un cilindro rotante su un albero coassiale ed ingranaggi scorrevoli su guide laterali, in grado di imprimere al rotolo un movimento di espulsione a velocità programmabile



Green technology: hypoid gearbox - Green technology: trasmissione ipoide

The main mechanical gearbox is a hypoid type instead of standard gears. The hypoid gear sets out from the pinion shaft the crown wheel (ring gear) axis, which enables the pinion to be larger in diameter and have more contact area. Using this main transmission gearbox to the take-up rollers allows 30% reduction in energy consumption. With a corresponding reduction in noise.

Riduttore meccanico principale tipo ipoide al posto degli ingranaggi standard. L'ingranaggio ipoide decentra il pignone rispetto alla corona e consente al pignone di essere più grande in diametro e di avere più superficie di contatto. L'utilizzo di questo riduttore principale per l'azionamento dei rulli di trazione permette di ridurre del 30% il consumo di energia. La trasmissione è molto silenziosa.

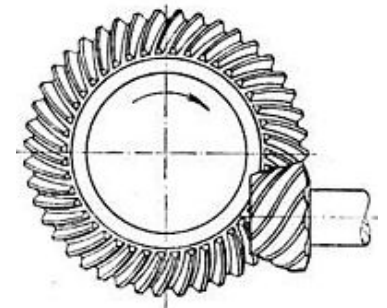

Adjustable electromagnetic Torque limiter - Limitatore di coppia elettromagnetico regolabile



The electronic limiter, particularly useful in the production of delicate fabrics, allows to adjust the slip and the torque between the two pulling cylinders.

A knob on the console allows an easy set-up, even when the machine is in motion.

Il limitatore elettronico, particolarmente utile nella produzione di tessuti delicati, consente di regolare lo scorrimento e la coppia tra i due cilindri di trascinamento.

Una manopola sulla consolle permette un set-up facile, anche con la macchina in moto.

Stop-start system – Sistema antichiarella

Tension on the cloth is gently reduced at each stop of the loom and brought back to the condition immediately prior to the stop when the loom restarts.

This function is used to prevent signs of stop/start marks.

La tensione sul tessuto viene delicatamente ridotta ad ogni fermata del telaio e ripristinata al valore precedente alla fermata quando il telaio riparte.

Questa funzione è utile per prevenire difetti sul tessuto determinati dalla fermata del telaio

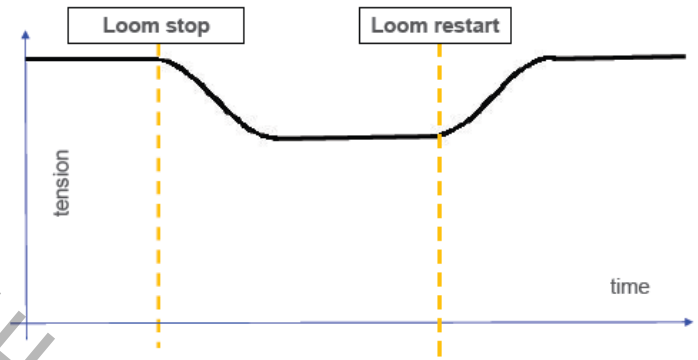

Panel with Joy-Stick - Joy-Stick sulla consolle



IP66 Echo LED Waterproof- high performance lights - Illuminazione tavola ispezione tessuto con LED Echo IP66



continuous alignment

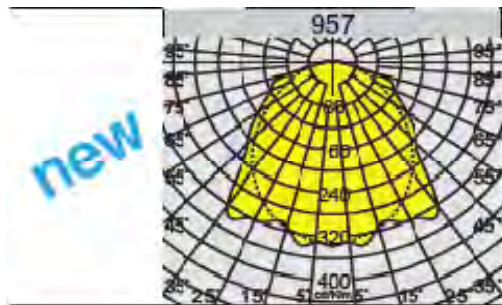

ALL LIGHT: no glare
The special surface finish of the diffuser allows light to escape, creating an "all light" effect. The fluted diffuser spreads light evenly without leaving dark areas.



Greater performance
The fixture is made with first-choice polycarbonate stabilised against UV light. It has been treated to eliminate glare without affecting performance.

USB port - Connessione USB



USB 3.0 High Speed

The USB socket for a 22 mm dia. push-button panel uses latest-generation USB 3.0 connectors, in order to offer maximum data transfer speed. Moreover, the socket is also backward compatible with previous USB connectors.

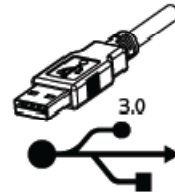

The USB port, as well as allowing the collection of diagnostic data, allows the firmware update when a new future releases.

La porta USB, oltre a permettere la raccolta di dati diagnostici, consente l'aggiornamento del firmware in caso di future release

A1000 OMRON-YASKAWA 3-phases Inverter – Inverter trifase



Display and self-diagnosis

equipped with display giving data on the electronic drive parameters. This performance life monitor also notify the user of electronic parts wear and maintenance periods to prevent problems before they occur.

Display e autodiagnosi

Il display evidenzia i parametri dell'azionamento elettronico. Questo monitor informa anche l'utente sull'usura di parti elettroniche e sui periodi di manutenzione per prevenire i problemi prima che si verifichino.

Excellent motor drive performance:

A1000 is a premium inverter drive running not only induction motors, but also PM motors (open and closed loop) with full torque at zero speed.

Built-in functional safety features:

The implemented Safe Torque Off (STO) function significantly improves machine safety and reliability.

Optimized machine efficiency:

Advanced energy-saving control technology which improves efficiency and machine productivity in combination with induction and PM motor operation. The 3 phases vectorial inverter has lower energy consumption than the one phase model, because there is not loss of energy in the transformer.

Prestazioni eccellenti di controllo dell'azionamento

L'inverter trifase, tecnologicamente avanzato, può pilotare motori ad induzione e motori PM (ad anello aperto o chiuso) con coppia massima anche a velocità zero.

Funzioni di sicurezza integrate

La specifica funzione STO (Safe Torque Off) incrementa la sicurezza e l'affidabilità della macchina.

Efficienza eccezionale

La superiore tecnologia di controllo a risparmio energetico aumenta l'efficienza e la produttività della macchina.

L'inverter vettoriale trifase ha un consumo di energia inferiore rispetto al modello monofase, perché non esiste perdita di energia nel trasformatore.

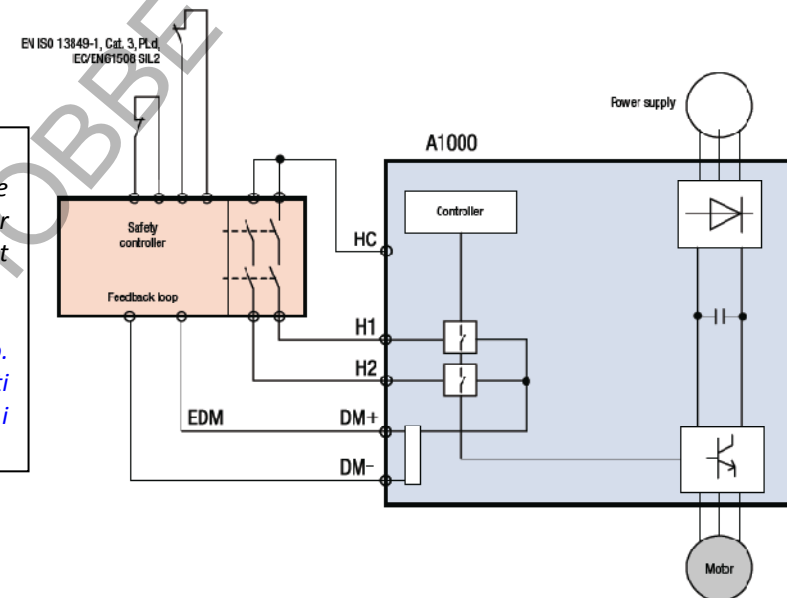

AST TANGENTIAL UNDER-LOOM BATCHING UNIT - AVVOLGITORE AST SOTTO TELAIO

Takes-up the fabric directly between the frames of the loom - Avvolge il tessuto direttamente sotto il telaio

Das Gerät wickelt das Gewebe direkt unter dem Webstuhl - **Le dispositif enroule le tissu directement sous le métier à tisser** - El dispositivo enrolla la tela directamente debajo del telar - **O dispositivo enrola o tecido diretamente sob o tear-** Cihaz şasi altında doğrudan kumaşı rüzgarlar –
 قفأل ايف حولت جي سننلا تحت قرش ابم جي سننلا حايير زاهچلا - **Устройство ветры ткань непосредственно под ткацкого станка**

Compact and ergonomic design - Design compatto ed ergonomico- Kompaktes und ergonomisches Design - Design compact et ergonomique - Diseño compacto y ergonómico O design compacto e ergonómico - Kompakt ve ergonomik yapı - Компактный и эргономичный дизайн - حيرمو طوغضم ميمصت

Perfect tension of the fabric from the beginning to the end of the roll - **perfetta tensione del tessuto da inizio a fine rotolo** - perfekte Spannung des Gewebes vom Anfang bis zum Ende der Rolle - **parfait tension du tissu du début à la fin du rouleau** - perfecta tensión de la tela desde el principio hasta el final del rollo - **tensão perfeita do tecido, desde o início até ao fim do rolo** - Mükemmel gerilim başlangıçtan tam sarılmış kumas topuna kadar - **идеально натяжение ткани от начала до конца рулона** –

قفأل قياهن یتحو قیادبلا نم جي سننلا نم يلاشم رتوتلا

The fabric tension adjustable - **tensione tessuto regolabile**- die Tuchspannung einstellbar- **la tension du tissu réglable**- la tensión de la tela ajustable - **a tensão da tela ajustável**- Kumas gerilimi serbestçe ayarlanabilir - **ткань натяжение регулируется** - لي دعتلل لبقا جي سننلا رتوتلا



The AST replaces the take-up unit in the weaving machine, which normally drives a fabric roll in the center. Thanks to the compact design, it is possible to place the AST within the weaving machine and therefore no additional space is required. A retrofit of existing machines as well as the installation into new weaving machines is possible.

L'avvolgitore tangenziale AST sostituisce quello usuale. Grazie alla sua compattezza viene installato all'interno delle spalle del telaio. E' anche possibile il retrofit.

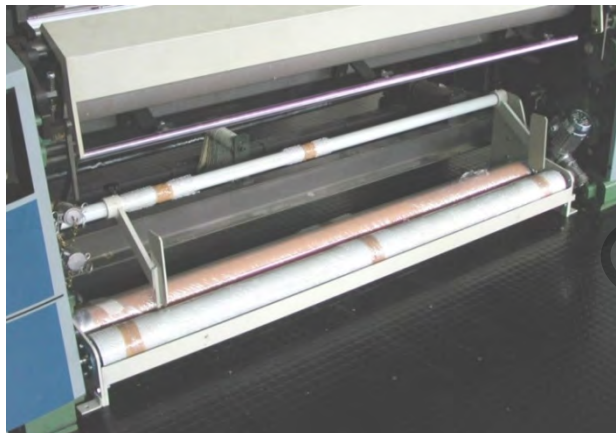

Version with Motor on the RH – Versione Motorizzazione a destra

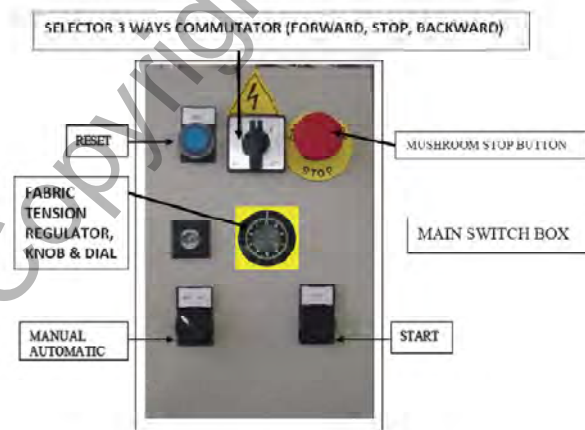

Version with Motor on the LH – Motorizzazione a sinistra

The AST automatic batching motion, placed under looms, is ideal to make small fabric rolls. Electronic INVERTER actuator automatically controls the fabric tension during the winding process. The electrical panel and the motorisation enable to handle all batching motion winding functions independently and safely.

L'avvolgitore AST, sotto il telaio, è l'ideale per ottenere piccoli rotoli di tessuto di qualità. L'attuatore elettronico ad INVERTER vettoriale controlla automaticamente la tensione del tessuto durante il processo di avvolgimento. Il quadro elettrico e la motorizzazione consentono di gestire tutte le funzioni di avvolgimento in modo indipendente e sicuro.

CUSTOMIZED SOLUTIONS - SOLUZIONI PERSONALIZZATE

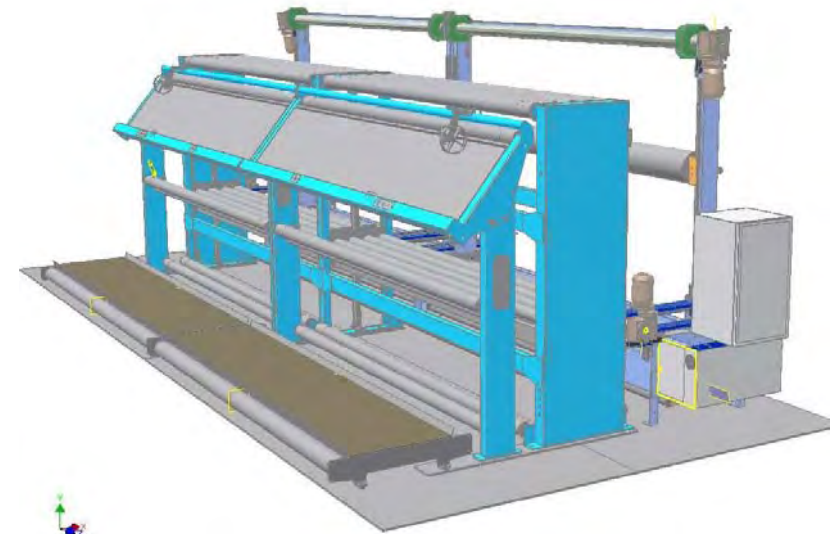
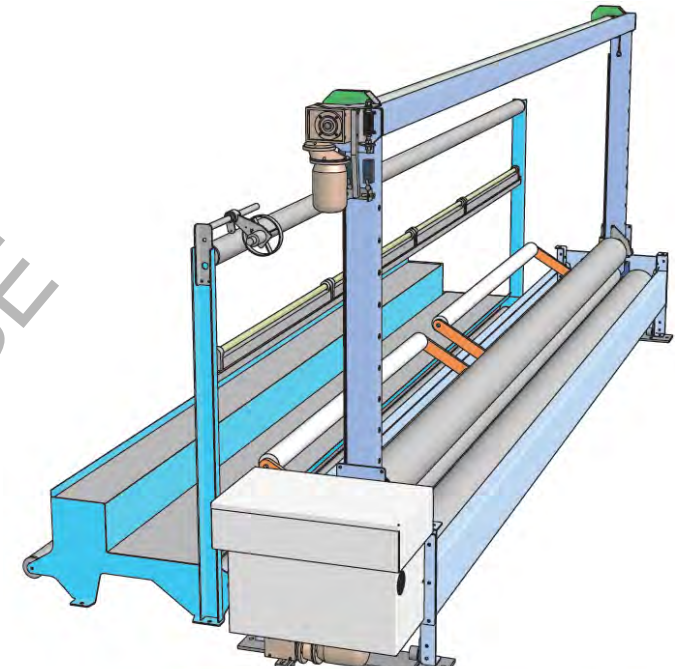
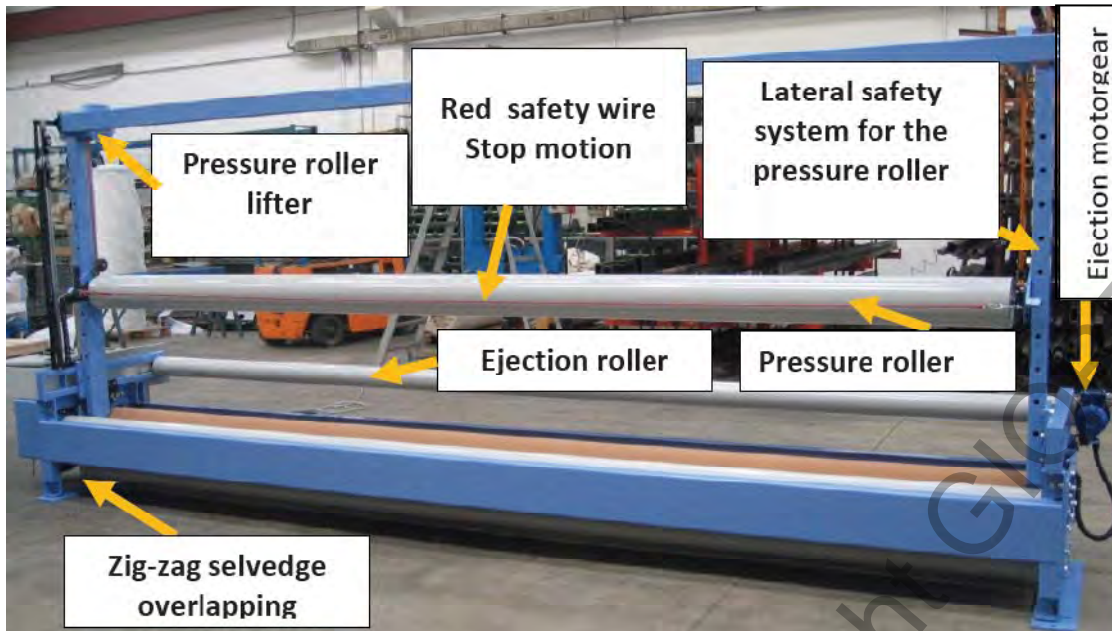

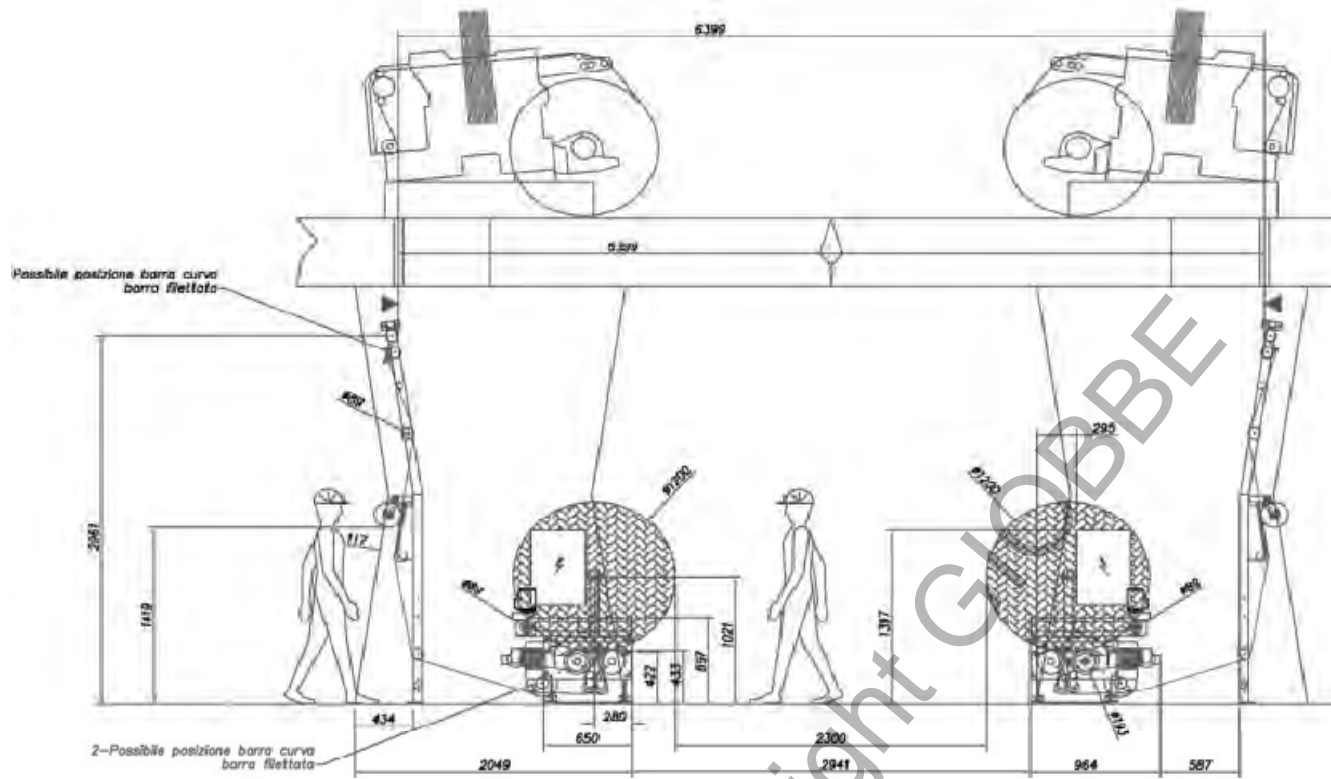

AVAILABLE OPTIONS - ACCESSORI E SISTEMI OPZIONALI

Among the many optional features that can offer we want to draw your attention to: - Tra i molti opzional disponibili si segnalano i seguenti :
Unter den vielen verfügbaren Optionen gehören die folgenden: - De nombreuses options sont disponibles parmi lesquelles:
Entre las muchas características opcionales de reciente desarrollo se ofrecen las siguientes : - Entre muitas opções disponíveis, inclui o seguinte :
Mevcut olan birçok seçenek arasında aşağıdakiler yer alır: - Среди многих опционально доступны включают следующее:
يولي ام لمشت ةحاتملا دي دعالا يرايت خا نيب:

Forward/reward alternated movement system for alternative overlapping of selvages, with variable stroke and adjustable linkwork connected to the main transmission. The lap machine is supported by bearings on guides to be ground fixed

Sistema di movimento alternato di sovrapposizione delle cimosse, con corsa e tempo variabili e programmabili. La macchina è supportata da cuscinetti di supporto scorrevoli su guide fissate sul pavimento.



Wrinkle Removers – Cilindri anti-piega



Wrinkle Removers - Cilindri anti-piega
Teflon Sleeve Rubber Expander Roller
- Rulli espansori con manica in teflon
Grooved Spreader Rollers- Rulli espansori scanalati
Metal Expanders - Espansori di metallo
Rubber Expanders - espansori di gomma
Curved bar - Barra curva

Green technology

Philips Maxos LED offers the best-in-class energy saving whilst delivering high lux levels at the required color temperatures and glare factors.

Lifetime to 70% luminous flux : 50000 hr

Lampade a LED Philips Maxos ad alte prestazioni, consentono risparmi energetici best-in-class, offrendo livelli elevati di lux alla temperatura colore richiesta, con annullamento di fattori abbaglianti. Lifetime al 70% del flusso luminoso: 50000 hr



Suction unit – Dispositivo di aspirazione



Remote-Service-Control - Controllo remoto

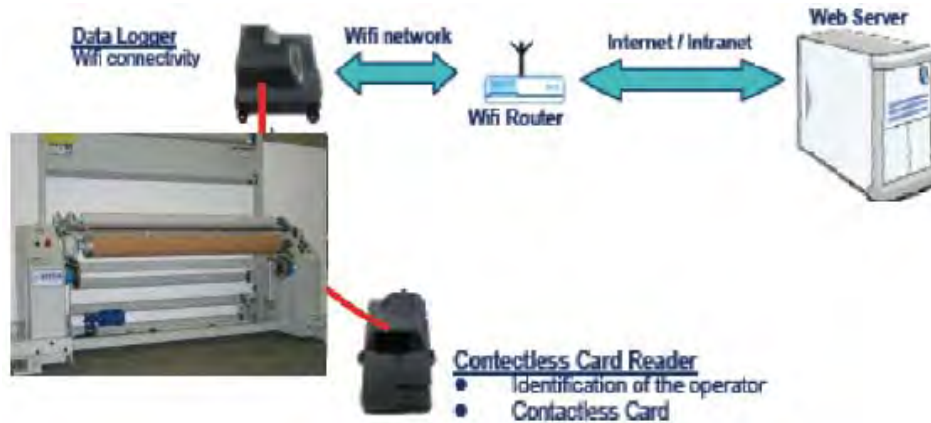

This system allows an immediate control, the analysis in case of malfunction, and replacement of the machine parameters.

With the CAN-BUS system all the data are available. Everywhere in the world, the data can be sent via Internet to our engineers for testing and for immediate assistance. The Controller Area Network (CAN) is a serial communication, which allows real-time monitoring with a high level of security. On request it is also available the Ethernet protocol.

Questo sistema permette un controllo immediato e l'analisi remota in caso di malfunzionamento. Con il sistema CAN-BUS tutti i dati sono disponibili. Ovunque nel mondo i dati possono essere inviati, via Internet, ai nostri tecnici per la verifica e l'assistenza immediata. Gli aggiornamenti del firmware e la sostituzione dei parametri macchina possono essere effettuati. Il Controller Area Network (CAN) è un modo di comunicazione seriale, che supporta in modo efficiente in tempo reale un altissimo livello di controllo di sicurezza.

Integrated Automation - Automazione integrata

Industrial Automation: The Factory Today and Tomorrow

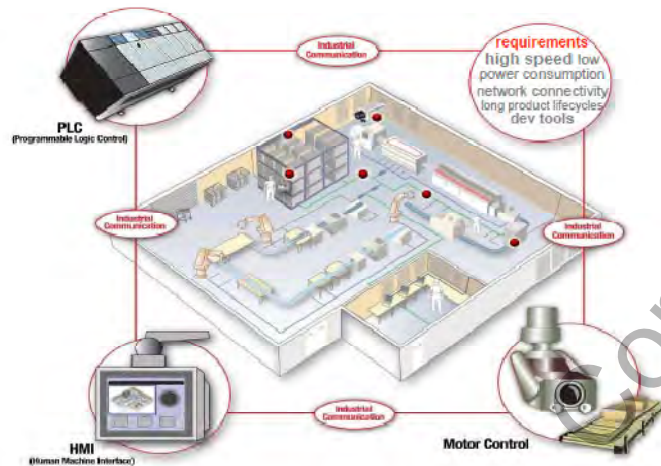

- Network connectivity (Ethernet, Wi-Fi®)
- Multiple connectivity and interface options (CAN, USB, SDIO, LCD I/F, I2C, SATA, PWM)
- interfaces (graphics acceleration)
- Operating system compatibility (Linux, Windows® Embedded CE, and Others)
- Scalability (broad portfolio of product options with code compatible roadmap)
- Processor: the modern TI SITARA multicore DSP or TI-Cortex
- Connettività - Connettività di rete (Ethernet, Wi-Fi®)
- Connettività multipla e opzioni di interfaccia (CAN, USB, SDIO, LCD I / F, I2C, SATA, PWM)
- interfacce di accelerazione grafica
- Compatibilità del sistema operativo (Linux, Windows® Embedded CE, e altri)
- Scalabilità (scelta di prodotti compatibili con il sistema)
- Scalabilità (vasta gamma di opzioni di supporto roadmap)
- Processore: TI DSP multicore SITARA o TI-Cortex

Safety light curtains - Barriere elettroniche di sicurezza

- segment display - display a segmenti
- Impact- and scratch-resistant front screen - schermo frontale antigraffio e resistente agli urti
- External device monitoring (EDM) and restart interlock (RES) - monitoraggio esterno del dispositivo (EDM) e riavvio (RES)
- Standard M12 connectivity - connettività M12 standard



The batching motions can be unloaded with FERBER trucks models CR, BZS, BZ2
 Gli arrotolatori possono essere scaricati con i carrelli FERBER modelli CR, BZS, BZ2
 Die Gewebewickelmaschinen können durch LKW FERBER Modelle CR, BZS, BZ2 entladen werden
 Les enrouleurs peuvent être déchargés par charriots FERBER modèles CR, BZS, BZ2
 Los arrolladores pueden ser descargados por carretillas FERBER modelos CR, BZS, BZ2
 Os enroladores podem ser descarregados por carrinhos FERBER modelos CR, BZS, BZ2
 Ayrı kumaş sarma üniteleri FERBER CR, BZS, BZ2 modeli arabalarla çalışmaya uygundur
 Оболочки могут быть выгружены на грузовиках Фербер модели CR, BZS, BZ2
 CR، BZS، BZ2 FERBER تان حاشل قطس اوب اه غي رفت ن كمي فل آ جي سن ل

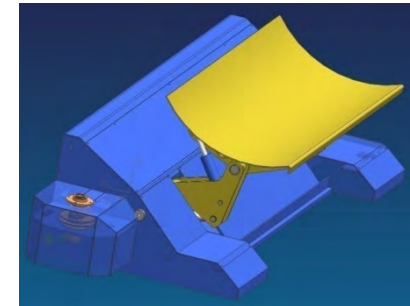

Ferber® and Ferber Textile Solutions®



Sono marchi registrati di: / are registered Trade Marks owned by: / sont des marques déposées appartenant à: sind eingetragene Warenzeichen von Besitz; / يتم تسجيل العلامات التجارية التي تملكها / son marcas registradas propiedad de: / Marcas registradas de propiedad da / Her hakkı mahfuzdur / являются зарегистрированными товарными знаками, принадлежащими компании;

GIOBBE S.r.l., Via Primo Maggio, 33 - 23873 Missaglia – Italy P.IVA-VAT 01665640130

WEB sites:

www.giobbeautomation.com

www.ferber.it

In USA see also- www.langligon.com/products.html

email: info@giobbeautomation.com

vermarktung@ferber.it

Technical Assistance:

ferberassistenza@giobbeautomation.com



Associato a Confindustria Lecco



Attività fondata nel 1840 dall'artiere fondatore Giovanni Beretta e condotta senza interruzione dai discendenti



Know-how-Schutz :

Diese Unterlage enthält Zeichnungen, Fotos und technische Daten des Produktes. Im Falle rechtswidriger Nutzung behalten wir uns das Recht vor, Schadenersatz geltend zu machen
BESCHERMING VAN DE KNOW-HOW - tekeningen, foto's, technische informatie. Dit document bevat tekeningen, foto's en technische details van het product. In het geval van illegaal gebruik, behouden wij ons het recht voor om actie te ondernemen voor de erkenning van onze rechten.

SALVAGUARDIA DEL KNOW-HOW – disegni, foto, informazioni tecniche.

Questo documento contiene disegni, fotografie e dettagli tecnici del prodotto. In caso di utilizzo illegale, ci riserviamo di agire per il riconoscimento dei nostri diritti.
SAUVEGARDE DU SAVOIR-FAIRE - dessins, photos, INFORMATION TECHNIQUE Ce document contient des dessins, des photographies, des détails techniques du produit.
En cas d'utilisation illégale, nous nous réservons le droit d'agir pour la reconnaissance de nos droits.

保護訣竅 - 圖紙，圖片，技術信息。

這個文件包含圖形，照片和產品的技術細節。

如遇非法使用，我們保留採取行動的認可是我們的權利。

Salvaguarda de los CONOCIMIENTOS TÉCNICOS - DIBUJOS, FOTOS, INFORMACIÓN TÉCNICA

Este documento contiene dibujos, fotografías, detalles técnicos del producto. En caso de uso ilegal, nos reservamos el derecho de actuar por el reconocimiento de nuestros derechos

Salvaguarda do propriedade intelectual - desenhos, fotos, informações técnica

Este documento contém desenhos, fotografias, detalhes técnicos do produto. Em caso de uso ilegal, reservamos o direito de agir para o reconhecimento dos nossos direitos

Know-how koruma: Bu belge, çizimler, fotoğraflar ve teknik detaylar içerir. Yasadışı kullanımı durumunda, tazminat talep etme hakkımızı saklıdır.

ノウハウ保護 - 図面、写真、技術情報。

このドキュメントでは、図面、写真、製品の技術的な詳細が含まれています。

不正使用の場合には、当社は当社の権利の認識のために行動をとる権利を留保します。

ةينقتلا تامول عمل او روص ل او تاموسرلا - ةياردلا ةي امح

جتن مل ةينقتلا لي صاقتلا او ، روص ل او ، تاموسرلا ةق يثول ا هذه ن مضا تتو

انقوي حب فسارتع ال ةمزال ال اءار ج ال اذاختا يف ق حلاب ظفتحن ن حنو ، عورش مل ا ريغ م اءختس ال ا ل ا ح يف

ЗАЩИТА НОУ-ХАУ - рисунки, фотографии, технические данные. Этот документ содержит рисунки, фотографии и технические детали продукта. В случае незаконного использования, мы оставляем за собой право принять меры для признания наших прав.

કેવી રીતે જાણવા રક્ષણ - રેખાંકનો, ચિત્રો, ટેકનિકલ જાણકારી.

આ દસ્તાવેજ રેખાંકનો, ફોટોગ્રાફ્સ અને ઉત્પાદન ટેકનિકલ વિગતો સમાવે છે.

ગેરકાયદે ઉપયોગ કિસ્સામાં, અમે અમારા અધિકારો માન્યતા માટે પગલાં લેવા માટે અધિકાર અનામત છે.

SKYDD AV know-how - ritningar, bilder, teknisk information.

Det här dokumentet innehåller ritningar, fotografier och tekniska detaljer om produkten. Vid olaglig användning, förbehåller vi oss rätten att vidta åtgärder för erkännande av våra rättigheter.

노하우의 보호 - 도면, 사진, 기술 정보.

이 문서는 도면, 사진, 제품의 기술적인 세부 사항이 포함되어 있습니다.

부정 이용의 경우에, 우리가 우리의 권리 인식 조치를 취할 권리.

SUOJELU OSAAMINEN - piirustuksia, kuvia, tekniset tiedot.

Tämä asiakirja sisältää piirustuksia, valokuvia ja tekniset tiedot tuotteesta. Jos kyseessä on laitton käyttö, pidätämme oikeuden ryhtyä toimiin tunnustamiseksi oikeuksiamme.

OCHRANA know-how - kresby, obrazy, technické informace.

Tento dokument obsahuje kresby, fotografie a technické podrobnosti produktu. V případě nezákonného užívání, vyhradzujeme si právo podniknout kroky k uznání našich práv.

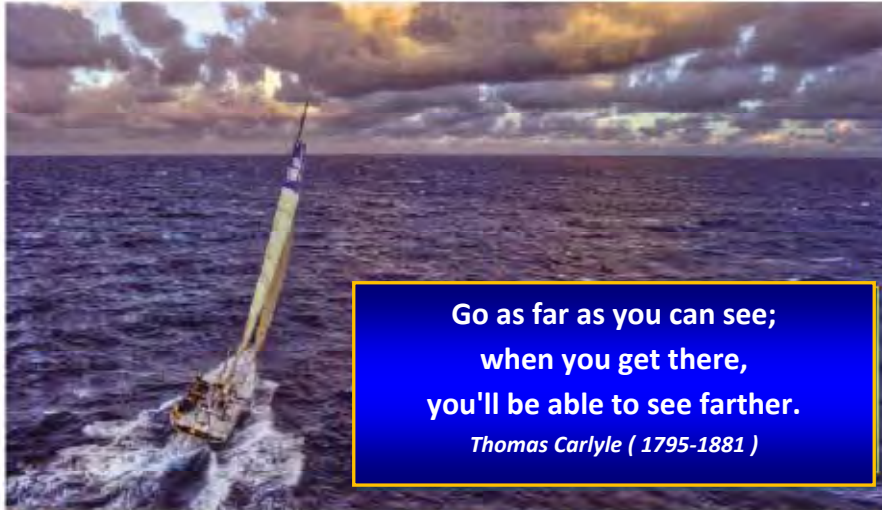

Go as far as you can see;
when you get there,
you'll be able to see farther.
Thomas Carlyle (1795-1881)

